

1000HP, 260 PSI RENTAL BOILER

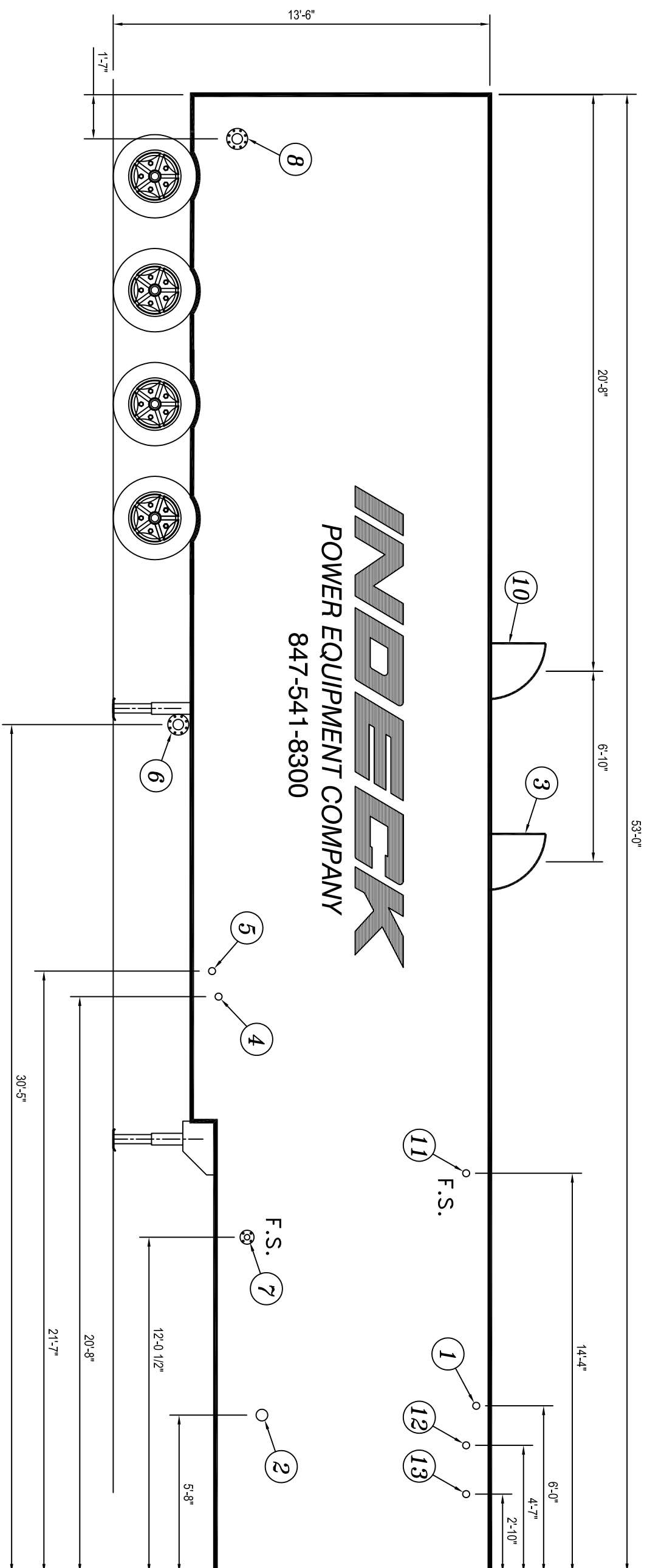

INDECK
POWER EQUIPMENT COMPANY
847-541-8300

INSTALLATION SERVICE CONNECTIONS

1. 2" NPTF MAKEUP WATER INLET (CONNECT CITY WATER SUPPLY - MIN 40 PSIG)
2. 1 1/2" NPTF 480/3/60 ELECTRICAL POWER CONNECTION PROVIDE 250 AMP, 480 VOLT, 3 PHASE, 60 HZ POWER SUPPLY WITH ADEQUATE GROUND
3. 6"-300# STEAM CONNECTION
4. 3/4" FUEL OIL RETURN
5. 3/4" NPT NO.2 OIL SUPPLY IF NO.2 OIL IS TO BE USED REMOVE CAP AND CONNECT OIL SUPPLY LINE. OIL PUMP IS CAPABLE OF LIMITED SUCTION LIFT. BETTER PUMP PERFORMANCE IS OBTAINED WITH FLOODED SUCTION CONNECTIONS
6. 3"-150# NATURAL GAS CONNECTION (TO BE REGULATED BY CUSTOMER)

7. 2" NPTF AUXILIARY FEEDWATER (FAR SIDE OF TRAILER)
8. 6"-150# PLANT DRAIN
9. N/A
10. BOILER FLUE GAS OUTLET AND COVER
11. 3/4" NPTF ATOMIZING AIR INLET
12. 2" NPTF HOT CONDENSATE RETURN
12. 2" NPTF COLD CONDENSATE RETURN

DESIGN DATA

OVERALL LENGTH: 53'-0"
 OVERALL WIDTH: 8'-6"
 SHIPPING WEIGHT (INCL TRAILER): 97,960 LBS
 OPERATING WEIGHT: 132,140 LBS
 CONTINUOUS CAPACITY: 1000 HP
 DESIGN PRESSURE: 290 PSIG
 GAS SUPPLY PRESSURE: 10.0 PSIG (REGULATED BY CUSTOMER)
 OIL SUPPLY PRESSURE: 57 PSIG MAX DP.
 FEED WATER PRESSURE: 40-100 PSIG MAX

NOTE: A NATURAL GAS OR PROPANE PILOT IS REQUIRED FOR OIL
 NOTE 2: PROVIDE ADEQUATE WEATHER PROTECTION FOR BURNER, CONTROLS AND PERSONNEL